

⑫ 実用新案公報 (Y 2) 平1-40545

⑬ Int. Cl. 4
A 63 F 9/22

識別記号 庁内整理番号
F-8403-2C

⑭ 公告 平成1年(1989)12月4日

(全3頁)

⑮ 考案の名称 感圧導電ゴムスイッチを備えたゲームコントロール装置

⑯ 実 願 昭60-172995

⑰ 公 開 昭62-82090

⑱ 出 願 昭60(1985)11月12日

⑲ 昭62(1987)5月26日

- ⑳ 考 案 者 河 島 庸 一 神奈川県平塚市南原1-28-1
- ㉑ 考 案 者 金 森 克 彦 神奈川県平塚市四之宮2432-2
- ㉒ 考 案 者 服 部 泰 神奈川県鎌倉市稲村ヶ崎5-36-5
- ㉓ 考 案 者 金 子 理 人 神奈川県平塚市南原1-28-1
- ㉔ 出 願 人 横浜ゴム株式会社 東京都港区新橋5丁目36番11号
- ㉕ 代 理 人 弁理士 小川 信一 外2名
- 審 査 官 神 悦 彦
- ㉖ 参 考 文 献 実公 昭53-28325 (J P, Y 2)

1

2

㉗ 実用新案登録請求の範囲

パーソナルコンピュータ用のゲームコントロール装置において、前記ゲームコントロール装置のスイッチに、押圧力によつて抵抗値が変化する感圧導電ゴムを使用し、この感圧導電ゴムスイッチに可変周波数型の発振回路を接続すると共に、この発振回路により制御される出力回路を設けたことを特徴とする感圧導電ゴムスイッチを備えたゲームコントロール装置。

考案の詳細な説明

〔産業上の利用分野〕

この考案は、押圧力によつて抵抗値が変化する感圧導電ゴムスイッチを備えたゲームコントロール装置に係わり、更に詳しくはパーソナルコンピュータやゲーム用コンピュータ等のゲームコントロールに係わる装置のスイッチを、その押圧力によつてコンピュータに送る信号の開閉周期を自在に制御出来るようにしたゲームコントロール装置に関するものである。

〔従来技術〕

従来、例えばコンピュータ用ゲームコントローラーは、1個又は2個のON/OFFスイッチと、2組の可変抵抗器によつて構成され、可変抵抗器の出力はカーソルの移動等に用いられ、ON/OFFスイッチの信号はTVゲームのミサイル、ピ

ストルの発射等に用いられている。

このON/OFFスイッチは1回押すと1回ONするだけなので、機能が単純であり、ミサイルを連射したいときなどは、不都合であった。

〔考案の目的〕

この考案は、かかる従来の問題点に着目して案出されたもので、その目的とするところは、コンピュータ用ゲームコントローラーのスイッチを感圧導電ゴムスイッチと可変周波数発振器を用いて出力回路を任意の周期で開閉できるようにすることで、ゲームの面白味を増すことができるようにした感圧導電ゴムスイッチを備えたゲームコントロール装置を提供するものである。

〔考案の構成〕

この考案は、上記目的を達成するためパーソナルコンピュータ用のゲームコントロール装置において、前記ゲームコントロール装置のスイッチに、押圧力によつて抵抗値が変化する感圧導電ゴムを使用し、この感圧導電ゴムスイッチに可変周波数型の発振回路を接続すると共に、この発振回路により制御される出力回路を設けたことを要旨とするものである。

〔考案の実施例〕

以下添付図面に基づき、この考案の実施例を説明する。

3

4

第1図はこの考案の回路図の一例を示し、1は抵抗、2はコンデンサー、3は押圧力によつて抵抗値が変化する感圧導電ゴム（例えば特公昭56-9187号公報、特公昭56-54019号公報）を用いたスイッチ、4はNAND回路等のICであつて、これらの各構成要素により可変周波数型の発振回路10を構成している。また、5はリレー駆動用トランジスタ、6は前記可変周波数型の発振回路10により制御されるリレー（出力回路）である。

そして、前記可変周波数型の発振回路10の発振周波数は、感圧導電ゴムスイッチ3の抵抗値とコンデンサー2の容量によつて決定される。

前記、発振回路10からの出力はトランジスタ5をスイッチさせ、リレー6が駆動される。

したがつて、感圧導電ゴムスイッチ3の抵抗を押しによつて変化させれば、前記発振回路10の発振周波数が変化し、リレーの開閉周期を任意に調節することができる。

次に、第2図はこの考案のブロック図でありAは発振回路、Bは信号出力を働かせる為のドライブ回路、Cはドライブ回路Bによつて動作されるリレー等の出力回路であり、ここよりの信号がコンピュータ等に送られる。

従つて、このリレー6の開閉をゲームコントローラーのスイッチとして使用すれば、コンピュータによる開閉信号の周期を使用者が任意に制御できるようになる。

第3図に、この考案の実施例を実際にゲームコ

ントローラーのスイッチとして使用している場合の構成図の一例を示し、ゲームコントローラー11の把持部12に、前記感圧導電ゴムスイッチ部3、発振回路10、リレー6を組み込み、コンピュータ13等に接続して、前述した操作を行うようにしたものである。

〔考案の効果〕

この考案は、上記のようにパーソナルコンピュータ用のゲームコントロール装置において、前記ゲームコントロール装置のスイッチに、押圧力によつて抵抗値が変化する感圧導電ゴムを使用し、この感圧導電ゴムスイッチに可変周波数型の発振回路を接続すると共に、この発振回路により制御される出力回路を設けたため、ゲームコントローラーのスイッチ信号の開閉周期の使用者の指先による押圧で自由に制御できるので、コンピュータゲーム等を行なう上で新しい手法を使えるようになり、ゲームの面白味を増すことができる。又、新しいコントローラーが出現することで、新しいソフトウェアの開発も可能となる。

図面の簡単な説明

第1図はこの考案を実施した制御回路図、第2図はこの考案のブロック図、第3図はこの考案をゲームコントロール装置に把持部に実施した概略構成図である。

3……感圧導電ゴムスイッチ、6……リレー（出力回路）、10……発振回路、11……ゲームコントローラー。

第1図

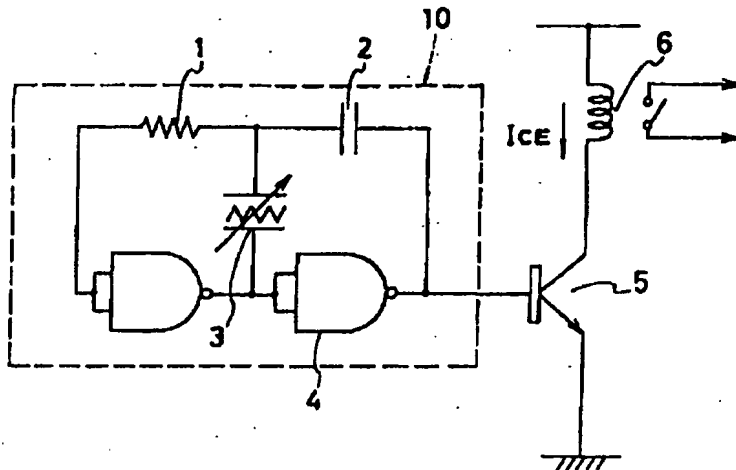

第2図

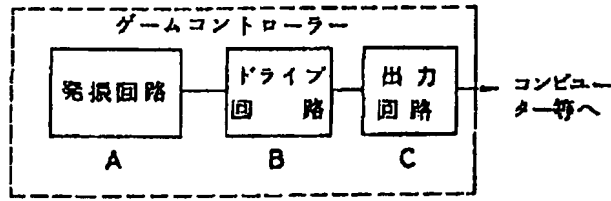

第3図

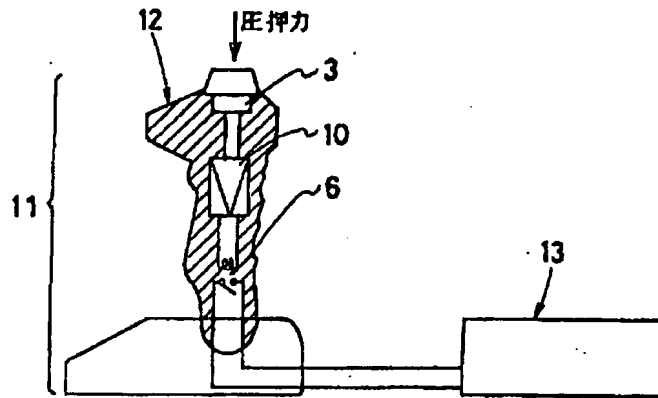



los angeles

portland

miami

toronto

lima

london

santo domingo

Translation Certificate of Accuracy

57031

Klarquist Sparkman, LLP

JP 1-40545_English.doc: Japanese-English patent translation

The above referenced document has been translated accurately, completely and reliably, and reviewed for cultural appropriateness by two qualified translators—one to translate and one to edit. No additions or deletions have occurred that would change the context of the source language message; content has not been altered or misrepresented; specific industry terminology has been used throughout; the reading level (linguistic register) of the original document has been maintained; and if adaptation of the reading level has been requested, target text has been adapted following Client's instructions.

The translators translating the materials have professional translation experience, full fluency in the target language of the materials, the ability to read and understand the source language, knowledge and experience with the culture(s) of the intended audience, and adequate knowledge of the subject matter.

This Certificate of Accuracy is hereby issued within the limits set forth by NetworkOmni's Terms and Conditions. The signing representative acknowledges that the information related to the above referenced document is privileged and confidential communication, and that reproduction of said materials is strictly prohibited without written authorization.

Tashia Stone

Printed Name of Certifying Representative

Sr. Translation Project Manager

Title

Tashia Stone

Signature

November 27, 2006

Date

H1-40545

| | | | |
|---|---|--|---------------------------------------|
| (51) Int. Cl. ⁴ A 63 F 9/22 | Identification Symbol | JPO File No. F-8403-2C | (24)(44) Publication December 4, 1989 |
| (3 pages total) | | | |
| (54) Title of the Device | Game control device equipped with pressure sensitive conductive rubber switch | | |
| | (21) Utility Model Application: S60-172995 | (65) Publication S62-82090 | |
| | (22) Filing Date: November 12, 1985 | (43) S62 May 26, 1987 | |
| (72) Inventor | Yasushi KAWASHIMA | 1-28-1 Minamihara, Hiratsuka-shi, Kanagawa-ken | |
| (72) Inventor | Katsuhiko KANAMORI | 2432-2 Shinomiya, Hiratsuka-shi, Kanagawa-ken | |
| (72) Inventor | Yasushi HATTORI | 5-36-5 Inamuragasaki, Kamakura-shi, Kanagawa-ken | |
| (72) Inventor | Masahito KANEKO | 1-28-1 Minamihara, Hiratsuka-shi, Kanagawa-ken | |
| (71) Applicant | Yokohama Rubber Co., Ltd. | 5-36-11 Shinbashi, Minato-ku, Tokyo | |
| (74) Agent | Shinichi OGAWA, Patent Attorney | and 2 others | |
| Examiner | Nobuhiko KAMI | | |
| (56) Reference Literature | Utility Model Publication S53-28325 (JP, Y2) | | |

[57] Scope of Registered Utility Model Claims

A game control device for a personal computer equipped with a pressure sensitive conductive rubber switch, wherein a pressure sensitive rubber is used whose resistance value changes with the pressing force on the switch of the above game control device and an output circuit is provided which, along with connecting a variable frequency oscillation circuit to this pressure sensitive conductive rubber, is controlled by this oscillation circuit.

Detailed Description of the Device

[Industrial Field of Application]

This device pertains to a game control device equipped with a pressure sensitive conductive rubber switch whose resistance value changes with pressing force, and more particularly, relates to game control device that enables a switch in a device for game control in personal computers or game computers to freely control the opening and closing cycle of signals sent to the computer by that pressing force.

[Prior Art]

In the past, for example, a computer game controller would consist of one or two On/Off switches and two groups of variable resistors, with the output of the variable resistors being used for cursor movements and the signals of the On/Off switch being used in the firing of missiles or pistols in a TV game.

The functions of this On/Off switch were simplistic because it would turn on only once if pressed once, and it was a drawback when someone wanted to launch a missile.

[Purpose of the Device]

Because it was conceived with a focus on such existing problems, an object of this device is to provide a game control device equipped with a pressure sensitive conductive rubber switch that is able to elevate the appeal of the game by designing a switch for a computer game controller so that it is capable of opening and closing an output circuit with a given frequency by utilizing a variable frequency oscillation circuit with pressure sensitive conductive rubber.

[Constitution of the Device]

This device, in a game control device used in a personal computer for achieving the aforementioned object, is one whose essential element consists of using pressure sensitive rubber whose resistance value changes with the pressing force on the switch of the above game control device and equipping it with an output circuit which, along with connecting a variable frequency oscillation circuit to this pressure sensitive conductive rubber, is controlled by this oscillation circuit.

[Embodiment of the Device]

We will explain an embodiment of this device on the basis of the attached drawings below.

3

Fig. 1 shows an example of the circuit diagram for this device, in which 1 is a resistor, 2 is a capacitor, 3 is a switch using pressure sensitive conductive rubber (as in, for example, Published Examined Application No. S56-9187 or Published Examined Application No. S56-54019) whose resistance changes with pressing force, 4 is an IC such as a NAND circuit, and variable frequency oscillation circuit 10 is constituted by each of these elements. In addition, 5 is a relay drive transistor and 6 is a relay (in the output circuit) controlled by the above variable frequency oscillation circuit 10 (output circuit).

The oscillation frequency of the above variable frequency oscillation circuit 10 is then determined by the resistance value of the pressure sensitive conductive rubber switch 3 and the capacity of capacitor 2.

As described above, the output from the above oscillation circuit 10 is switched by transistor 5, and relay 6 is driven.

Accordingly, if the resistance of the pressure sensitive conductive rubber switch 3 is changed by the pressing force, the oscillation frequency of oscillation circuit 10 changes and the opening and closing cycle of the relay can be adjusted at will.

Next, Fig. 2 is a block figure of this device in which A is an oscillation circuit, B is the drive circuit for controlling the signal output, and C is an output circuit such as a relay that is operated by the drive circuit B and signals from here are transmitted to the computer.

Thus, if the opening and closing of this relay 6 is used for the game controller switch, the user will be able to control the cycle of opening and closing signals via the computer at will.

In Fig. 3, we illustrate an example of a structural diagram

4

when the embodiment of this device is used as an actual game controller switch. Here, pressure sensitive conductive rubber switch 3, oscillation circuit 10, and a relay 6 are incorporated into the casing 12 of game controller 1 and are connected to computer 13 to perform the above operations.

[Effect of the Device]

Because this device utilizes a pressure sensitive conductive rubber whose resistance value changes with pressing force in a game control device for a personal computer and is provided with an output circuit which, along with connecting a variable frequency oscillation circuit to this pressure sensitive conductive rubber, is controlled by this oscillation circuit in the manner described above, the opening and closing cycle of the switch signal of a game controller can be freely controlled by pressing force from the finger of the user, so it will allow the use of new techniques in playing computer games and elevate the appeal of the games. Additionally, with the development of a new controller, the development of new software will also become possible.

Brief Explanation of Drawings

Fig. 1 is a control circuit diagram in which this device has been implemented, Fig. 2 is a block diagram of this device, and Fig. 3 is an outline configuration diagram in which this device is implemented in the casing on a game control device.

3.....pressure sensitive conductive rubber switch; 6.....relay (output circuit); 10.....oscillation circuit; 11.....game controller.

Fig. 1

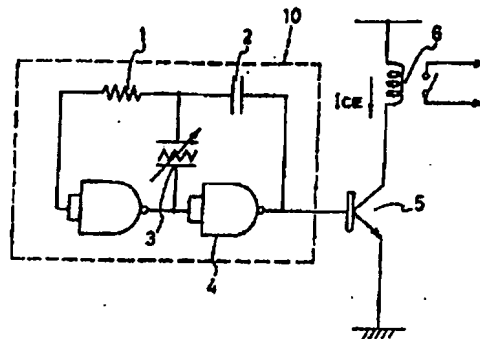
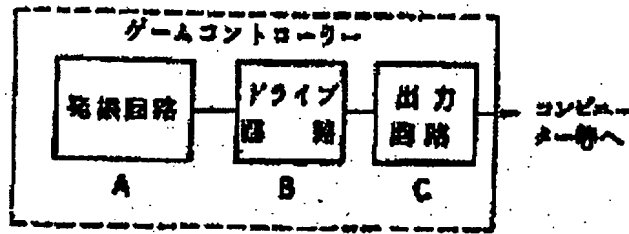

Fig. 2



[Callouts:]

[top middle] Game controller

A - Oscillation circuit

B - Drive circuit

C - Output circuit

[right] To computers

Fig. 3

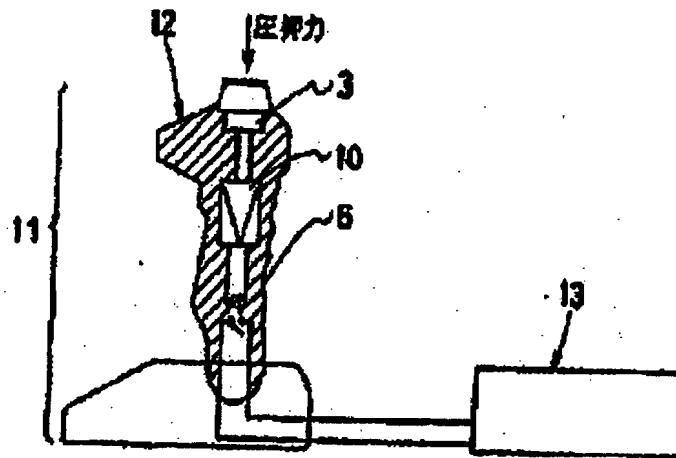

[Callouts:]

[top] Pressing force



los angeles
portland
miami
toronto
lima
london
santo domingo

Translation Certificate of Accuracy

57031
Klarquist Sparkman, LLP
JP 1-40545_English.doc: Japanese-English patent translation

The above referenced document has been translated accurately, completely and reliably, and reviewed for cultural appropriateness by two qualified translators—one to translate and one to edit. No additions or deletions have occurred that would change the context of the source language message; content has not been altered or misrepresented; specific industry terminology has been used throughout; the reading level (linguistic register) of the original document has been maintained; and if adaptation of the reading level has been requested, target text has been adapted following Client's instructions.

The translators translating the materials have professional translation experience, full fluency in the target language of the materials, the ability to read and understand the source language, knowledge and experience with the culture(s) of the intended audience, and adequate knowledge of the subject matter.

This Certificate of Accuracy is hereby issued within the limits set forth by NetworkOmni's Terms and Conditions. The signing representative acknowledges that the information related to the above referenced document is privileged and confidential communication, and that reproduction of said materials is strictly prohibited without written authorization.

Tashia Stone

Printed Name of Certifying Representative

Signature

Sr. Translation Project Manager

November 27, 2006

Title

Date